



---

BALDOR-RELIANCE® NEMA MOTORS

# Severe Duty

## XT and XEX series

**BALDOR • RELIANCE**



---

## Local manufacturing and customer service

More than 100 years ago, we set out to build a better motor, and that's still our goal. Today, ABB is the world's number-one manufacturer of NEMA motors, and we're proud to support you locally with the Baldor-Reliance product brand. When you choose an ABB Baldor-Reliance motor, you get a product produced in the USA and backed by 100 years of heritage. Our motors are designed and built right here – in Arkansas, Georgia, Mississippi and Oklahoma – and our production facilities are committed to quality and dependability so that we can provide you with a reliable motor every time.

Our team understands the challenges you face to stay productive and profitable while meeting the demands of industry and government regulations. We realize the importance of American products to many of our customers, and we can help you navigate the standards and regulations in the industries in which you operate to provide you with the right product when you need it.

Every year, thousands of customers make the choice to trust ABB. Your success is our success, and we work with you every step of the way to deliver a motor that exceeds your expectations. We provide a simplified approach to providing industry-specific solutions, with next-generation products, shorter lead times and the ability to outpace other motor manufacturers with faster, more efficient output and support services.

The voice of our customers drives our strategy. You are the engine that helps guide decisions in our business. We strive to keep your applications running safely, reliably, effectively and sustainably, and we look for ways to continuously create value and provide a world-class customer experience. The same passion and pride you put into your business, we put into every motor we make. You don't settle for second best, and neither will we.



---

# A complete line of Severe Duty products

XT and XEX, there's uncompromised quality in both.

When it comes to performance, the XT is our versatile option to what the industry expects as "Severe Duty" – while the XEX is our premium severe duty motor that performs like none other in the industry.

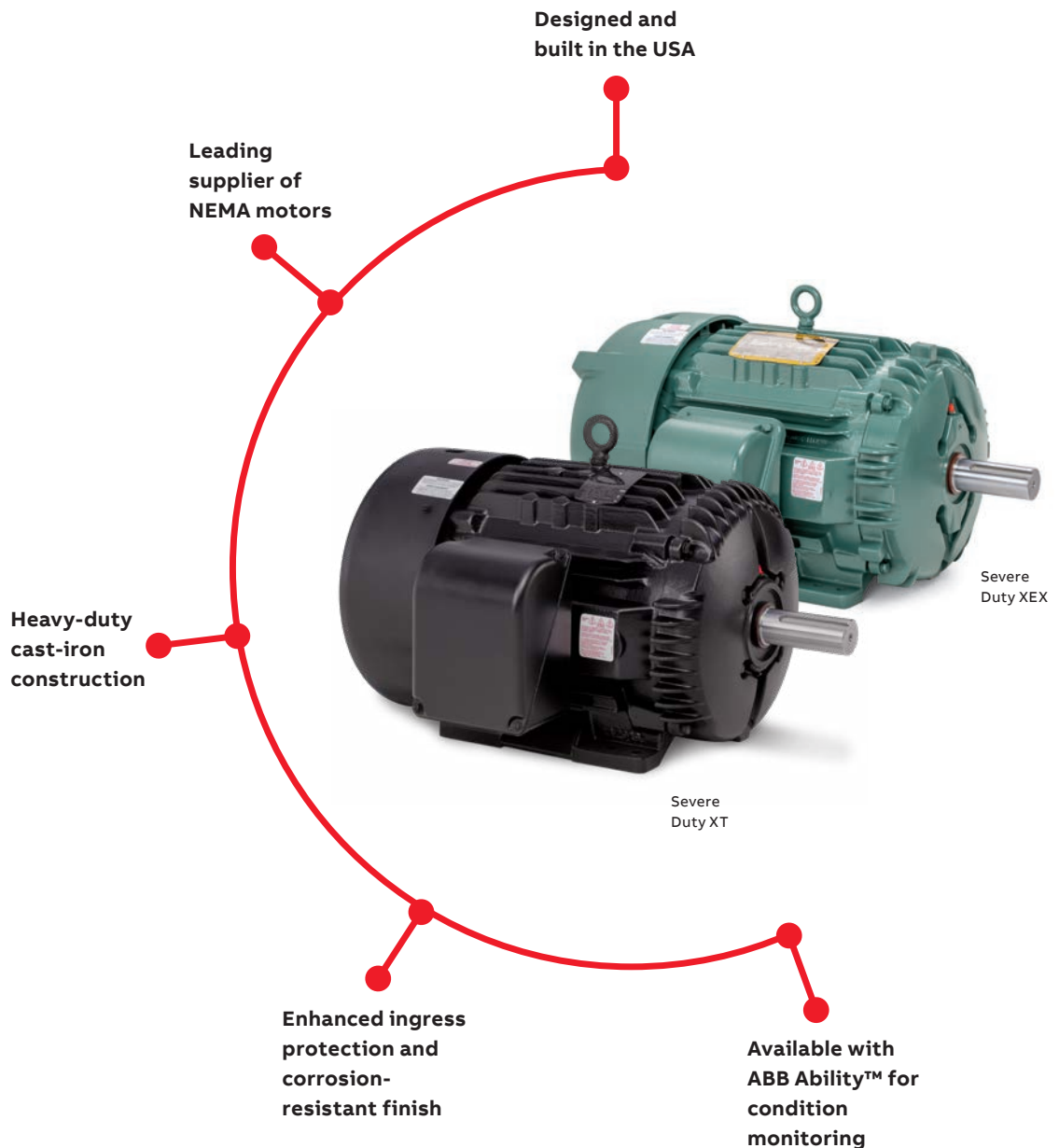

# Protection vs. performance



## What is protection?

What we can see

- Paint
- Sealing system
- Gaskets
- Enclosure material
- Drains
- Clear nameplate information



## What is performance?

Hidden, but provides customer benefit

- Vibration limits
- Low operating temperature
- Capable of withstanding voltage spikes
- Use on Variable Speed Drive
- Insulation life
- Bearing life



## Baldor-Reliance Severe Duty line

Uniquely suited for every rugged application



### Severe Duty product line

		<b>NEW</b> Severe Duty XT	Severe Duty XEX/ECP	IEEE 841XL*	661XL/ IEEE 841*	Crusher Duty	RPM XE	IEEE 841XL P-base*
<b>Frame sizes from stock</b>		143T-449T	143T-588	143T-449T	184T – 365T	184T – 588	215 -405	182 - 365
<b>Electrical features</b>								
<b>Efficiency</b>	Baldor-Reliance motors meet or exceed all efficiency requirements for US, Canada and Mexico requirements	•	•	•	•	•	•	•
	Efficiency two to four levels above NEMA premium, up to IE5 efficiency when run across the line						•	
<b>Torque</b>	NEMA Design B torques as a minimum	•	•	•	•		•	•
	NEMA Design A: High torque design exceed Design C					•		
<b>Voltage</b>	230/460 volt thru 100 hp, 460 volts 125hp and higher	•	•	•	•	•	•	•
	460 volts	•	•	•	•	•	•	•
	575 volts	•	•	•	•	•		
<b>Service factor and temp. rise</b>	1.15 service factor continuous	•	•	•	•		•	•
	1.25 service factor up to 100 Hp, 1.15 service factor over 100 Hp - continuous					•		
	Class F insulation with Class B rise @1.0 service factor	•	•	•	•	•	Class H	•
<b>Inverter</b>	Suitable for inverter use per NEMA MG 1 Part 31.4.4.2	•	•	•	•	•	•	•
<b>Mechanical features</b>								
<b>IP enclosure</b>		IP54	IP55/66	IP56	IP56	IP55/66	IP55	IP55
<b>Construction</b>	Cast iron frame	•	•	•	•	•	•	•
	All cast iron construction including endplates, conduit box and fan cover (586/7 frames have fabricated steel fan covers)		•	•	•	•		•
	All hardware is SAE zinc plated	•	•	•	•	•	•	•
<b>Conduit box</b>	Diagonally split, oversized rotatable conduit box (ease of connection and room for space heater leads)	•	•	•	•	•		•
<b>Leads</b>	Color leads	•	•	•	•	•	•	•
	Lead separating gasket – nipple design		•	•	•	•	•	•
<b>Extended durability</b>	T-drains to remove condensation	•	•	•	•	•	•	•
	Zerk fittings on all sizes	•	•	•	•	•	•	•
	Protective coating on rotor and stator	•	•	•	•	•	•	•
	Phase paper & coil head lacing	•	•	•	•	•	•	•
<b>Bearings &amp; lubrication</b>	Regreaseable bearings – PLS system		•	•	•		•	•
	Ball bearing designs – same size bearings on both ends		•	•	•		•	
	Oversized ball bearings up to 50 Hp, ball and roller bearing designs 60 Hp and up. 586/7/8 frames include oversized roller bearings on DE.					•		
<b>Paint</b>	Corrosion resistant 2 part epoxy paint system, exceeding 300 hrs. salt fog test per ASTM B 117	•	•	•	•	•	•	•
<b>Other key features</b>								
<b>Certifications and tests</b>	Vibration testing as standard			•	•			•
	Corona inception testing	•	•	•	•	•	•	•
	Documented final motor test – ships with motor			•	•	•		•
	UL® recognized, CSA certified markings	•	•	•	•	•	•	•
<b>Safety</b>	Meets and exceeds IEEE 841 and IEEE 45			•	•			•
	Heavy duty grounding lugs on frame		•	•	•	•	•	•
	Vertical lifting provisions for ease of installation				•			•
<b>Nameplate information</b>	Class I, Division 2 (Group A, B, C, , D) on standard NEMA frames	•	•	•	•		•	•
	Stainless steel embossed raised lettering		•	•	•	•	•	•
	Stainless steel laser etched lettering	•						
	Turn-down ratios on nameplate	•	•	•	•	•	•	•
<b>Reliability</b>	ABB Ability Smart Sensor ready	•	•	•	•	•	•	•
	Designed and built in the USA	•	•	•	•	•	•	•
	Warranty - in years from date of manufacture	3	3	5	5	3	5	5

\*These motors are designed to meet and exceed the requirements of IEEE Std. 841

# NEW XT series

## Severe Duty motors

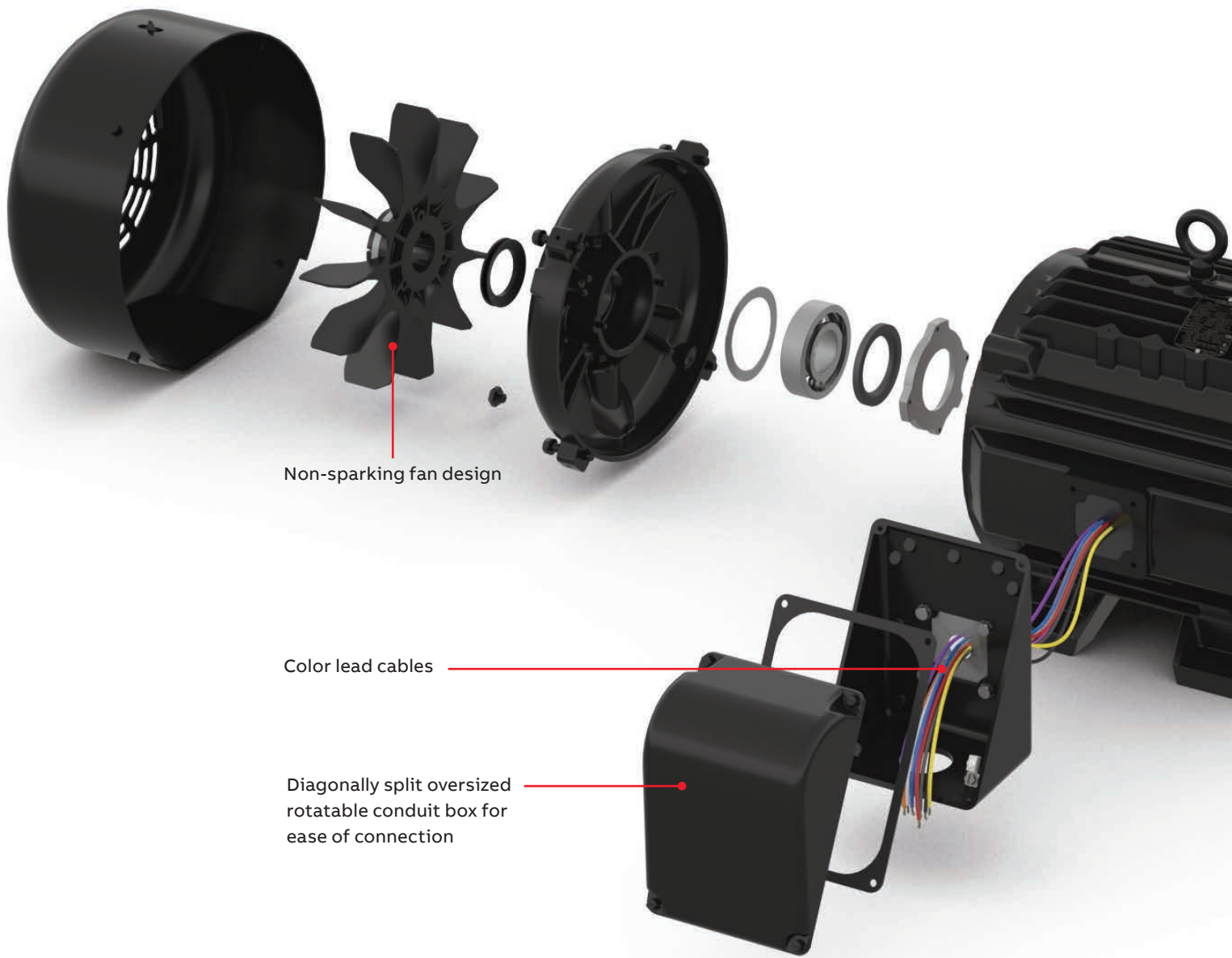

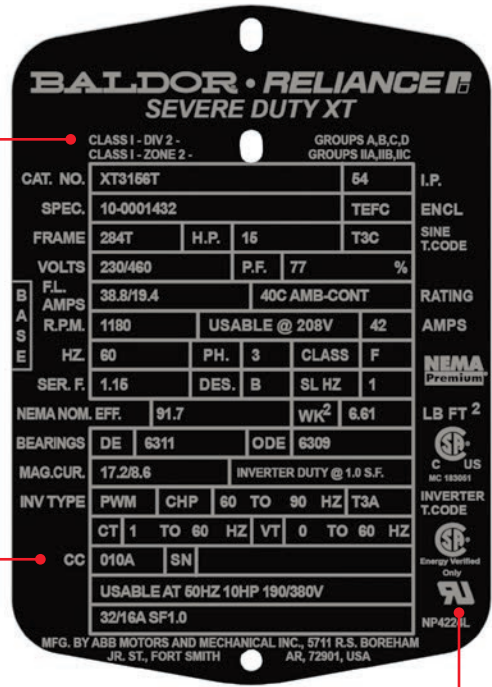

Division 2 markings  
Class I, Group A, B, C, D

Laser-etched inverter-duty nameplate

Certifications

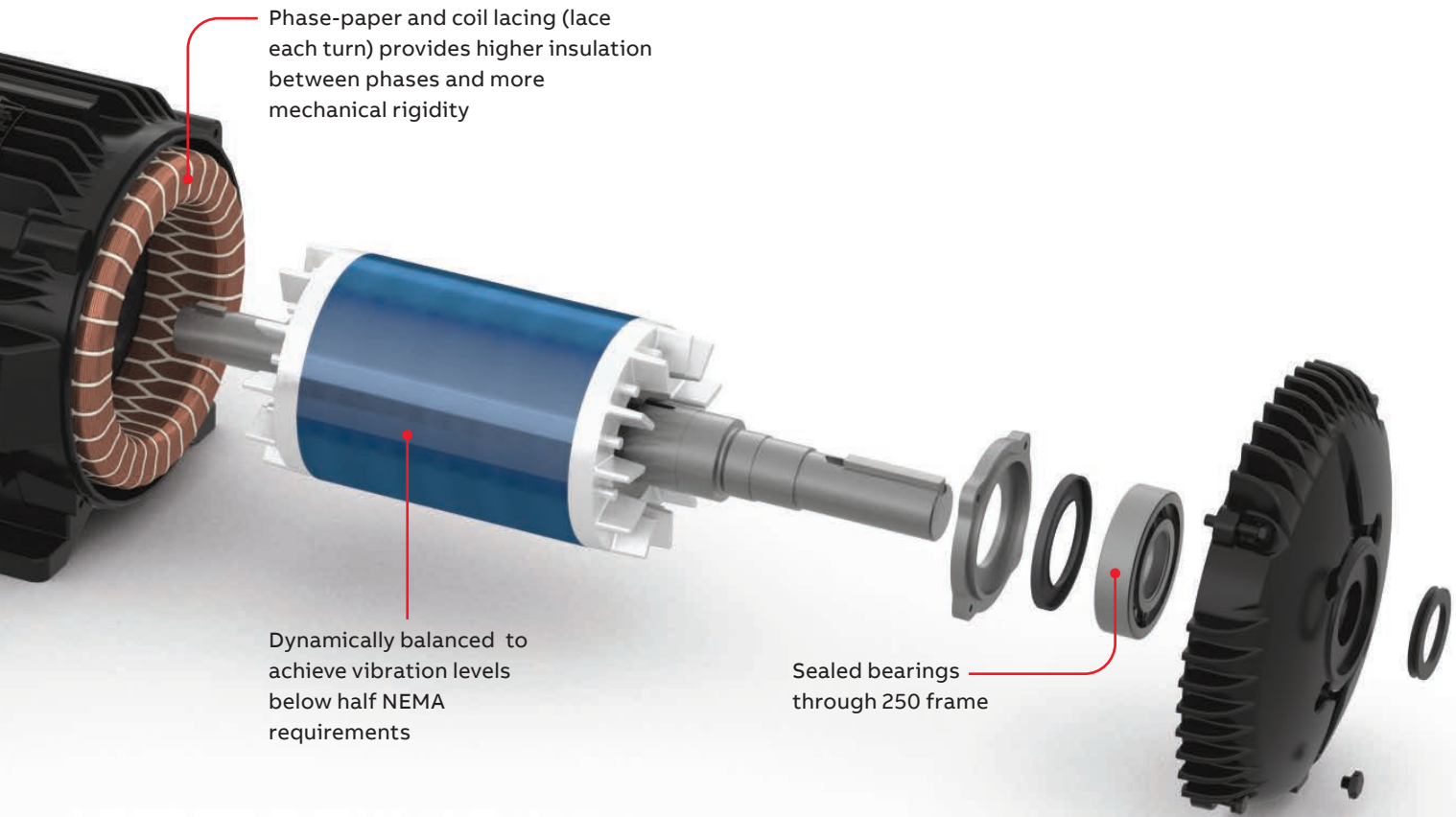

# Severe Duty XT

## The RIGHT solution

You need a motor that performs at its best in even the most extreme conditions, and ABB's Baldor-Reliance Severe Duty XT Series delivers. With rugged cast iron frames, condition monitoring capability and the most options right off the shelf, XT series motors give you exactly what you need to keep your business moving, safely and reliably.

XT motors are designed and built in the U.S. by the world's #1 NEMA motor manufacturer, so they're available for fast delivery and installation. Choose a motor with a reputation for quality that never backs down.



### Drop-in features for fast, easy installation



- ✓ **Same electrical features**
  - Inverter Duty
  - Division 2 nameplate for sine wave







- ✓ **Same mechanical features**
  - Cast iron construction
  - NEMA frame sizes, bearings and lubrication are the same



- ✓ **More industry experience**
  - Better coating
  - Better sealing design
  - Enhanced safety features



# Features that improve overall performance

Customer benefit	ABB offering	Features that matter
<b>Versatility</b> 	Off-the-shelf features that make this motor versatile for quick turnaround and suitable for variety of applications.	Inverter Duty Turndown ratios on nameplate Reduced voltage options can be used end of the line (usable at 208V) Can use both 50/60Hz F1/F2 installation flexibility Available from stock Cast-iron frames for all sizes
<b>Extended motor life</b> 	Performance enhancing features that make Baldor-Reliance the #1 brand in NEMA motors.	Balanced to half NEMA vibration Ingress protection (IP54) 2-part epoxy paint for corrosion protection Class F insulation with Class B rise at full load 1.15 service factor for overload protection T-drains Phase-paper and coil lacing (lace each turn) provides higher insulation between phases and more mechanical rigidity Zinc plated hardware 3-year warranty
<b>Safety</b> 	Safety is our #1 priority with safer installation, connection and operation making our motors the most reliable in the industry.	Grounding lugs in conduit box for ease of connecting leads Lifting provisions casted in for larger frame sizes (400 -440 frame) Suitable for hazardous locations (Class I, Div. 2) Non-sparking fans ABB Ability ready for remote condition monitoring
<b>Ease of maintenance</b> 	With maintenance in mind, we've designed our XT motors to be easy to install, connect, and conduct maintenance on for extended performance.	Oversized conduit boxes Color leads for ease of connection Standard SAE hardware Zerk fittings (280 frame and above) Laser etched nameplate Suitable for Smart Sensor (ABB Ability)
<b>Testing and certification</b> 	A trusted brand that provides proof of quality and durability.	300+ hour salt spray test on paint Corona inception testing UR component CSA (Class I, Division 2, NRTL certified for hazardous locations) NEMA premium efficient motor

# XEX Series

## Severe Duty motors

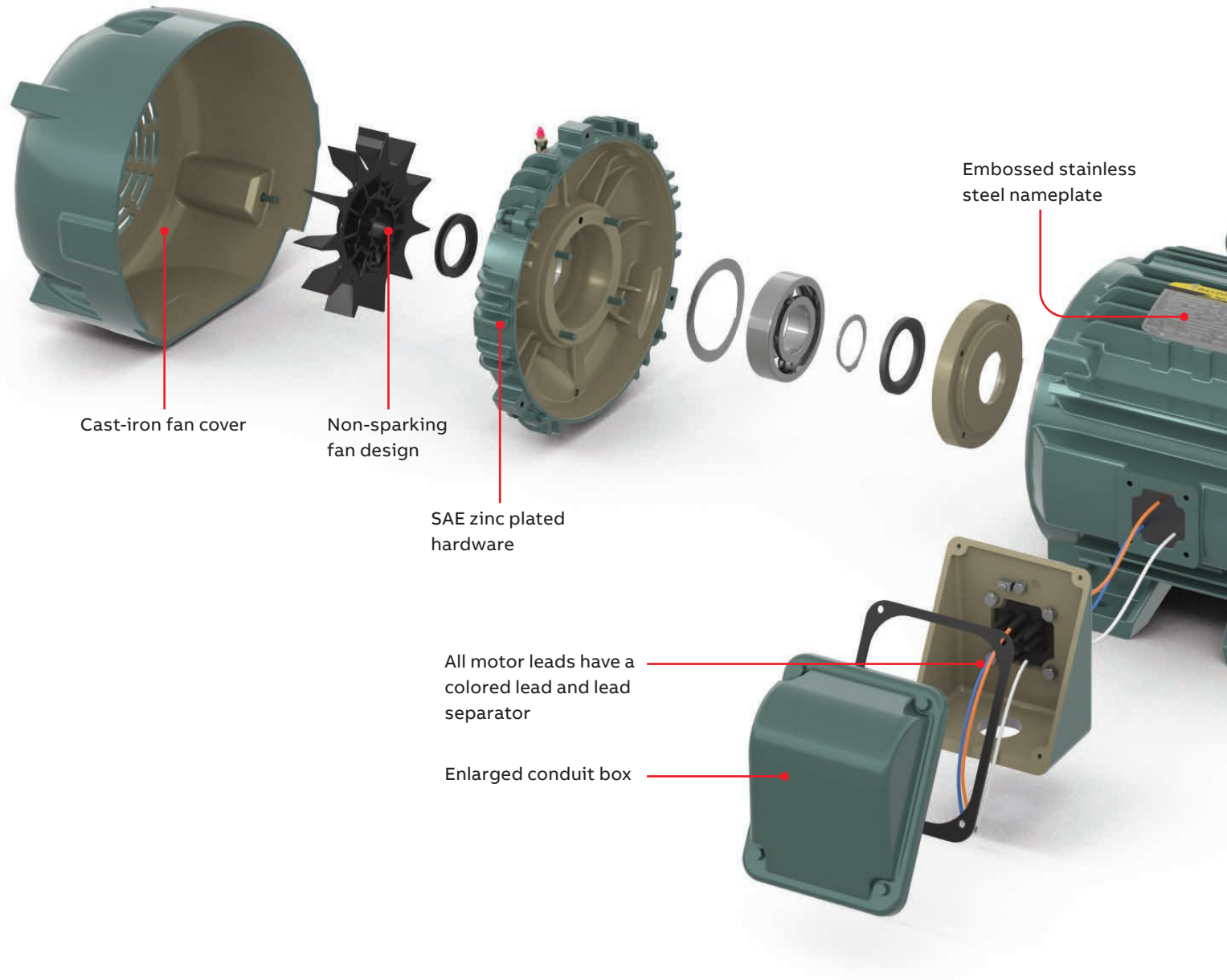

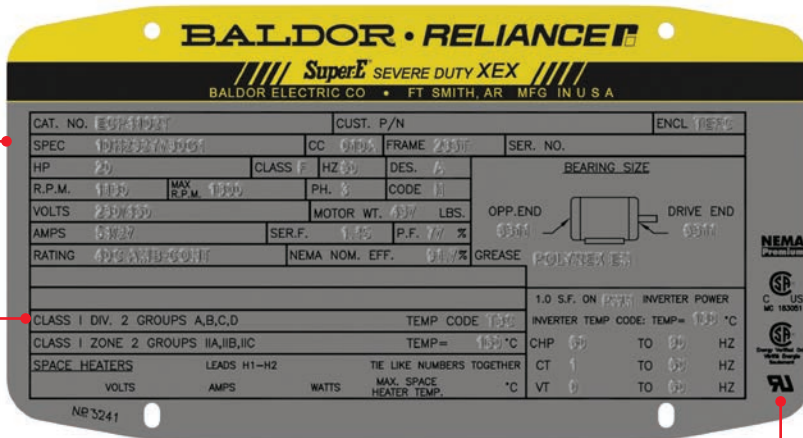

Stainless steel embossed nameplate

Class I, Division 2, Group A, B, C, D markings

Certifications

High-strength cast iron frame is designed to reduce vibration and assure accurate mounting dimensions



All internal rotor stator, and shaft surfaces are epoxy coated

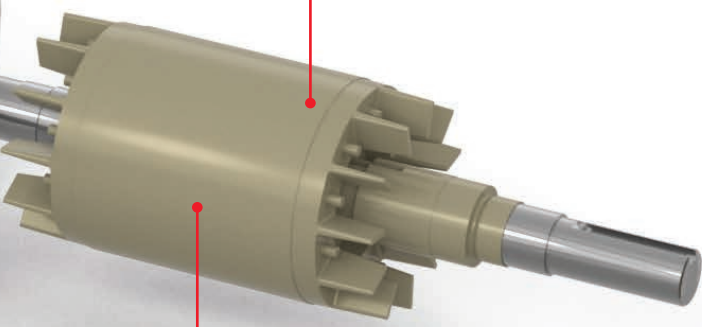

Dynamically balanced to achieve vibration levels below half NEMA requirements

Durable cast iron shield machined to close tolerances for bearing and rotor

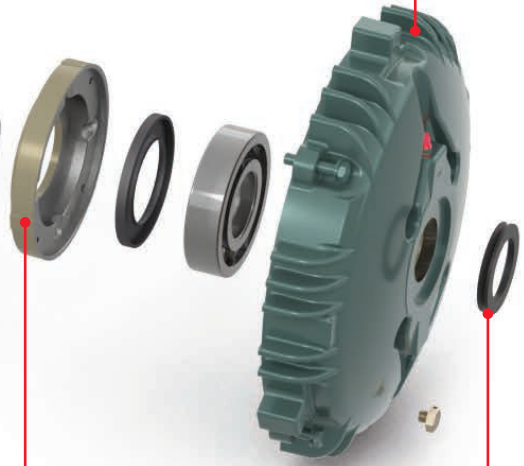

Cast iron bearing inner-caps provide accurate alignment and prevent contamination

Neoprene v-ring slingers at both drive end and fan end to ensure bearing protection from contaminants

# Severe Duty XEX

## Performance and Protection for any application

Challenging environments and difficult conditions require a motor that delivers peak performance, rain or shine, without disruptions. Between XT and IEEE 841 is the Baldor-Reliance Severe Duty XEX motor.

XEX motors provides safe, dependable operation and reduced energy consumption in the toughest applications. Built with a heavy-duty cast iron enclosure and regreasable bearings to maximize motor life, XEX motors can take anything you throw at it.

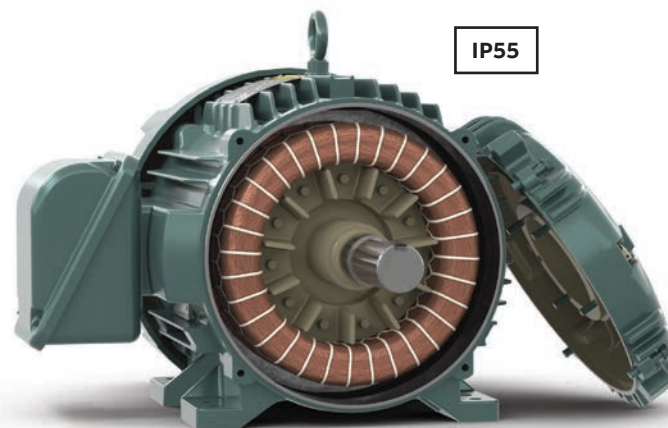

**Stock:** covers most applications



**Adjustable:** Multiple configuration mounting



**Modifiable:** Fully staffed and certified shop houses available



**Custom:** Endless array of solutions and designs



### Performance

**Built to conquer demanding applications.**  
Designed to withstand against severe duty applications with demanding service factor needs.

**Extended life.**  
Superior design allows the motor to run cooler.

**Flexible operation.**  
Premium design allows the motor to perform efficiently across the line or paired with a VFD.







### Protection

**We do not compromise.**  
Full cast iron design is across all frame sizes and parts. From the frame and endplate, down to the conduit box and internal parts.

**Control of your equipment.**  
Regreasable open bearings facilitate maintenance, and increase the life of the motor.

**It's the details that counts.**  
Threaded conduit box and lead separator gasket work together to keep contaminants out and keep interior clean.

# Features that improve overall performance

Customer benefit	ABB offering	Features that matter
<b>Versatility</b> 	Off-the-shelf features that make this motor versatile for quick turnaround and suitable for variety of applications.	Inverter Duty Turndown ratios on nameplate Reduced voltage options can be used end of the line (usable at 208V) Can use both 50/60Hz F1/F2 installation flexibility Shaft grounding available if Division 2 certification is removed Available from stock
<b>Extended motor life</b> 	Performance enhancing features that make Baldor-Reliance the #1 brand in NEMA motors.	Cast-iron construction throughout Balanced to half NEMA vibration Ingress protection (IP55) 2-part epoxy paint for corrosion protection Class F insulation with Class B rise at full load 1.15 service factor for overload protection T-drains Oversized bearings on both ends Protective coating on rotor and stator Phase-paper and coil lacing (lace each turn) provides higher insulation between phases and more mechanical rigidity Zinc plated hardware 3-year warranty
<b>Safety</b> 	Safety is our #1 priority with safer installation, connection and operation making our motors the most reliable in the industry.	Grounding lugs for ease of connecting leads, not necessary to drill and tap (for both conduit box and frame) Lifting provisions casted in for larger frame sizes (400 -440 frame) Lead separating gasket Suitable for hazardous locations (Class I, Div. 2) Non-sparking fans ABB Ability ready for remote condition monitoring
<b>Ease of maintenance</b> 	With maintenance in mind, we've designed our XEX motors to be easy to install, connect, and conduct maintenance on for extended performance.	Embossed stainless steel nameplate Oversized conduit boxes Regreasable open bearings facilitate maintenance and increase the life of the motor Color leads for ease of connection Standard SAE hardware Zerk fittings (250 frame and above) Suitable for Smart Sensor (ABB Ability)
<b>Testing and certification</b> 	A trusted brand that provides proof of quality and durability.	300+ hour salt spray test on paint Vibration testing Corona inception testing UL listed UR component CSA (Division 2, NRTL certified for hazardous locations) NEMA premium efficient motor

# ABB Ability condition monitoring for hazardous locations

The ABB Ability Smart Sensor for hazardous areas monitors the health and performance of rotating machines operating in explosive atmospheres.

## Sensor features

### Certified for hazardous areas

The ABB Ability Smart Sensor for hazardous areas is designed for harsh environments. Its enclosure withstands high vibration levels and protects the sensor from dust and water ingress and is rated IP66/67. The sensor is certified for ATEX, IECEx, and NEC500, making it compliant with the strictest requirements for equipment operating in explosive atmospheres.

### Health checks

Based on ABB's extensive know-how, advanced algorithms are used to analyze the data and produce meaningful information such as temperature, vibration, load, number of starts and more. The sensor sends this information directly to a smartphone or gateway and to a dedicated ABB Ability Smart Sensor portal. Data is also tracked over time for trend analysis.

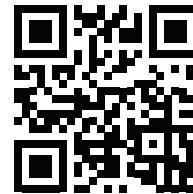

(For more information on ABB Ability smart sensors)

## Part information

Part number	Description	Application
3AFP9234751	Motor Smart Sensor for hazardous areas with aluminum bracket mounting tool	Ribbed cooled or finned cast iron motor
3AFP9225986	Motor Smart Sensor for hazardous areas with flat mount mounting tool	Rolled steel/round body motor
3AFP9234757	Motor Smart Sensor for hazardous areas without any mounting tool	
3AFP9253862	Flat mount mounting tool	
3AFP9253864	5 year subscription	
3AFP9191436	2 year subscription	
3AFP9127707	1 year subscription	

---

# ABB, your global value partner

Partnering with ABB gives you access to some of the world's most innovative technology and thinking.

## Global reach

ABB operates in over 100 countries with its own manufacturing, logistics and sales operations together with a wide network of local channel partners that can quickly respond to your needs. They bring our products and services straight to your front door. The ABB channel partners have in-depth knowledge of local markets and are conversant with the defined ABB products and processes.

## Energy efficiency

ABB has what it takes to help every industry and application reach new levels of efficiency and energy savings even under the most demanding conditions. Combining the best available materials with superior technology, our motors are designed to operate reliably no matter how challenging the process or application, and to have low life cycle costs.





---

**ABB Motors and Mechanical Inc.**

5711 R.S. Boreham, Jr. Street  
Fort Smith, AR 72901

**[new.abb.com/motors-generators](http://new.abb.com/motors-generators)**

